



ECM (Eight Channel Monitor)

Description

An integral part of the IKON AVS fault monitoring network, the ECM, is designed to monitor up to eight separate loudspeaker lines using a combination of methods to cater for virtually all possible contingencies.

The ECM is inserted between the amplifier and loudspeaker circuit. Using a combination of voltage comparison and current monitoring techniques the system can be configured for use with low impedance and 100V line systems.



Contents

DESCRIPTION	1
CONTENTS	2
ECM INTRODUCTION	3
MONITORING GUIDE	3
FUNCTIONALITY	4
FRONT PANEL CONTROLS SEE APPENDIX A	4
RS232 SEE APPENDIX B	4
REAR PANEL CONNECTIONS	5
<i>Amplifier and Speaker connections</i> See Appendix C	5
<i>Event input</i> See Appendix D	5
<i>Common Fault</i> See Appendix E	5
<i>Power Supply</i> See Appendix E	5
<i>Fibre Connectors</i> See Appendix F	5
CALIBRATION AND SETUP	6
APPENDIX A	7
ECM CALIBRATION	7
APPENDIX B	8
RS232 CONNECTING DETAILS	8
APPENDIX C	9
SPEAKER CONNECTIONS	9
<i>High impedance speaker monitoring</i>	9
<i>ECM wiring</i>	9
FAULT DETECTION	11
LINE LEVELS	11
LOW IMPEDANCE SPEAKER MONITORING	11
DETECTION WIRING	11
FAULT DETECTION	12
AUDIO CONNECTIONS 4 WIRE SYSTEM.	13
AUDIO CONNECTIONS 2 WIRE SYSTEM.	13
APPENDIX D	14
EVENT INPUT DESCRIPTION	14
<i>Configuration</i>	14
<i>Connections</i>	16
APPENDIX E	17
COMMON FAULT RELAY	17
POWER SUPPLY	17
DC POWER INLET	17
APPENDIX F	18
OPTICAL FIBRE CONNECTORS	18

ECM Introduction

Monitoring guide

The ECM is suitable for use on 100V line systems from 30w to 1Kw (or from 5w if using an EOL terminator) as well as low impedance systems ranging in power from 60w to 1Kw into 4 or 8 Ohms. Calibration is simple with the unit auto ranging to select the correct settings. The acceptance window for fault reporting is also automatically set with an option for the user to configure the system using the windows based software.

The system is configured to detect the presence of a low level 20KHz signal when no audio program is present. This signal is then used to process an accurate test of the load and line. When an audio program is detected, the monitoring process continues but with an increased window of acceptance to allow for variations in audio program material. The system will revert to 20KHz monitoring either at the end or during a break in audio program material.

The 20KHz signal needs to be introduced to the system either directly through a DSP sound engine or separately via an external oscillator.

A windows based software utility is available for use with the unit allowing simple system configuration and adjustments. The software allows unit identification, selection of monitoring type, configuration of the event input and common fault output as well as monitoring of mains & DC supplies.

Functionality

Front Panel Controls See Appendix A

Front panel controls allow calibration of the unit and LED's display the current status of each individual circuit.



◆ Each channel when calibrated will show its current status by the illuminated LED.

- Loudspeaker Cable, Load or Short Fault
- Loudspeaker Circuit OK

◆ Power LED's indicate the unit power rails are operating when illuminated.

◆ Fibre transmit and receive LED's illuminate when data is present on either primary or secondary fibres.

◆ The red LED illuminates when the set button is pressed for calibration.

RS232 See Appendix B

◆ Program the system via the RS232 port using the software utility.

Rear Panel Connections



[Amplifier and Speaker connections](#) See Appendix C

- ◆ Eight individual input/output speakon connectors are located on the rear panel.
- ◆ Connections from the amplifier output are connected to terminals marked 1+ and 1- respectively.
- ◆ Connections to loudspeaker circuits monitoring low impedance only connect 1+ and 1-.
For small 100V line circuits (max of 8 speakers) 1+ and 1- are used as the signal send and 2+ used for a third wire 'End of Line' return.
For larger 100V line circuits, or where complete rings are used, the 'End of Line' return is connected to 2+ and 2-.

[Event input](#) See Appendix D

Four opto-isolated inputs for connection to external sources. Typically used to monitor DSP processor or UPS status.

[Common Fault](#) See Appendix E

A change over relay provides a common fault output that can be configured to provide a change in status for any fault.

[Power Supply](#) See Appendix E

A 230V 50Hz mains supply socket. The mains fuse (T500mA 20mm) is mounted within this socket. The fuse carrier also contains a spare fuse.

A 24V DC battery backup input is also provided. The software utility allows status monitoring of both power supplies.

[Fibre Connectors](#) See Appendix F

Twin (primary & secondary) ST fibre connectors for incoming and outgoing fibre connections to other hardware in the system. The software utility allows either single or dual fibre operation with states of system verified and reported.

Calibration and Setup

- ◆ Press the Set button (top left). Red led will illuminate.
- ◆ Select all channels on unit to be calibrated using buttons 1 to 8.
- ◆ Play audio source at Max SPL approx. Audio must be present for a period of one minute (minimum).
- ◆ Press the set button (top left). Red led will now flash on and off.
- ◆ Then stop audio.
- ◆ Introduce 20KHz at low level and observe the yellow LED's above channel number.

● LOAD	If illuminated 20KHz to High
● SHORT	If illuminated 20KHz to Low
● OK	Illuminated to show channel selected

The OK LED and the Short LED should be illuminated to show the 20KHz signal to LOW.

Increase the 20KHz level until the Short LED goes out.

When only the OK led is lit on channels 1 to 8 press the SET button again and calibration is complete.

The OK LED should remain lit.

To test a circuit simply remove 20KHz signal and observe LED's on that channel. A LOAD fault should be shown illuminated.

Return the 20KHz signal and the OK LED should be shown illuminated.

Appendix A

ECM Calibration



The set button is used to calibrate the loudspeaker circuits.

- ◆ Press once and release (Red LED will illuminate)

To calibrate channel N.

- ◆ Press the button below channel N.
- ◆ Play the audio source at max SPL for 1 minute.
- ◆ Press the Set button once (Red LED and LED's below will flash alternately).

- ◆ Stop the audio.

- ◆ Introduce the 20KHz at low level.

- ◆ Observe the two LED's above the OK LED.
Short indicates that the 20KHz to low
Load indicates that the 20KHz to high
Adjust the 20KHz until both LED's are off.

- ◆ Once this is achieved press the set button to complete the calibration.

- ◆ The OK LED should now be illuminated.

- ◆ Test the circuit simply by removing the 20KHz signal.

- ◆ A load fault will be indicated after a short period.

- ◆ Return the 20KHz signal.

- ◆ The fault LED should be replaced by the OK LED.



Appendix B

RS232 Connecting Details

This is located on the front panel and provides a bi-directional RS232 port used to communicate with an IBM compatible PC.

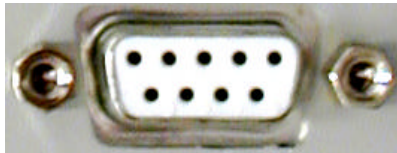

- Pin 1 No connection
- Pin 2 Serial data receive (RX)
- Pin 3 Serial data transmit (TX)
- Pin 4 No connection
- Pin 5 Ground
- Pin 6 No connection
- Pin 7 No connection
- Pin 8 No connection
- Pin 9 No connection

Appendix C

Speaker Connections

High impedance speaker monitoring

This is intended to monitor voltage driven multi-speaker lines, such as 100V systems. High impedance monitoring operates by measuring signal levels at the amplifier and the far end of the speaker line. Whilst three and four wire monitoring is preferable, it is also possible to use the two wire monitoring method recommended for low impedance circuits.

ECM wiring

This detection requires a pair of connections taken directly from the power amplifier and a second pair from the far end of the speaker line.

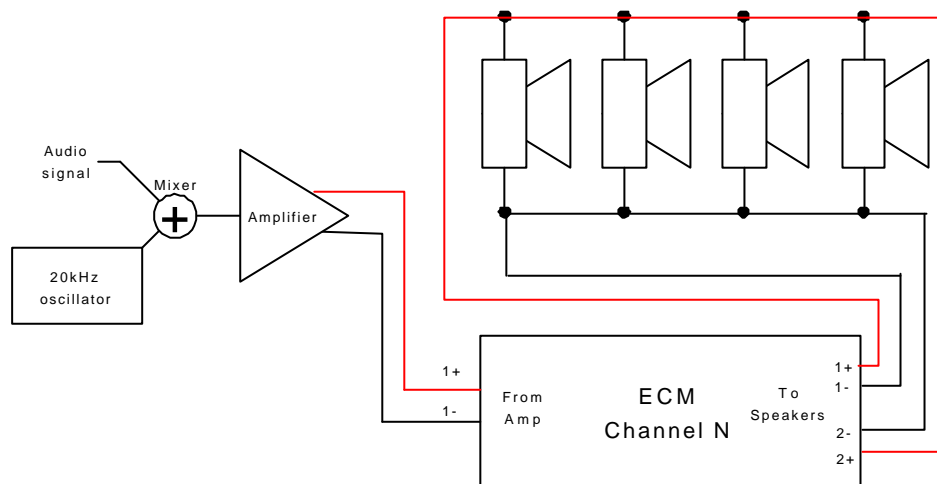

It is essential that the speaker lines contain no spurs, as these will not be monitored, as shown below.

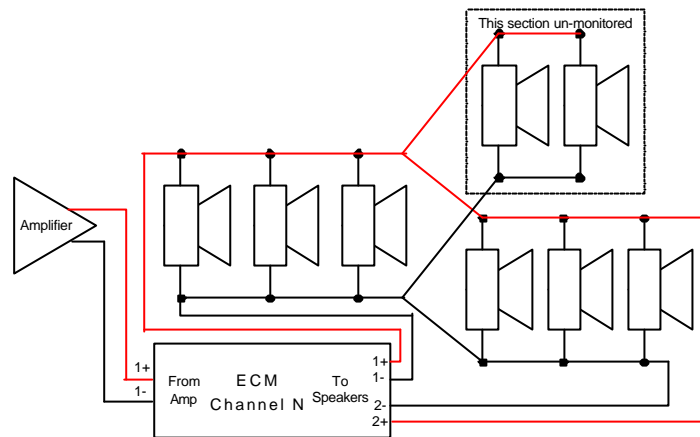

The solution below is not recommended. Impedance changes on either section of speakers will result in two faults on the system. Difficult to resolve and pinpoint where fault has occurred.

The most effective solution to spurs is to rewire as a separate circuit.

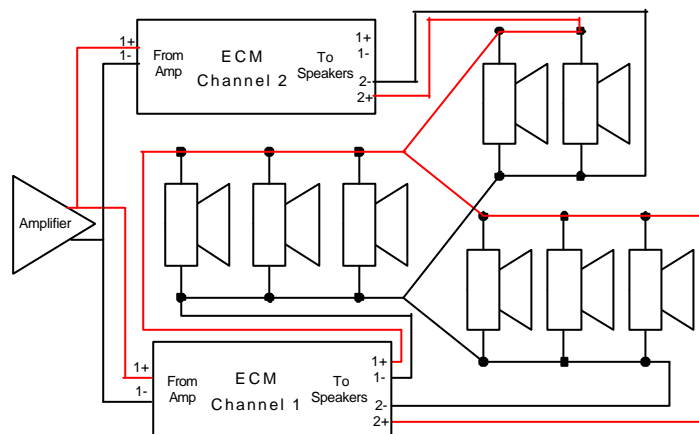

Fault detection

The speaker line is monitored for :-

1. **Cable fault**, a break in the speaker cable. This is detected by signal presence at the power amplifier and not at the far end of the speaker line.
2. **Load fault**, an excessive change in speaker line loading. This is detected when the speakers line attenuation changes by more than 20 percent. Attenuation here is power amp level divided by far end of speaker line level.
3. **Short fault**, a short on the speaker line or a failed power amplifier. This is detected by the absence of signal at the power amplifier.

Line levels

The unit can monitor signal levels from 20dBu to 100V line.

Low impedance speaker monitoring

This is intended to monitor an amplifier driving a single or small group of speakers. Low impedance monitoring measures the signal voltage and current from the output of the amplifier.

Detection wiring

Low impedance monitoring requires the amplifier output to be routed through the ECM unit, as shown below.

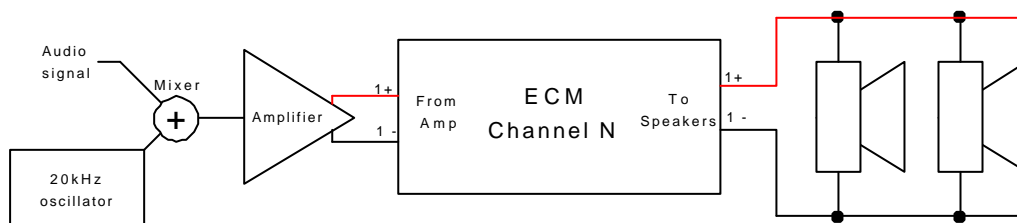

Series/parallel circuits, shown below are monitored by this mode of detection.

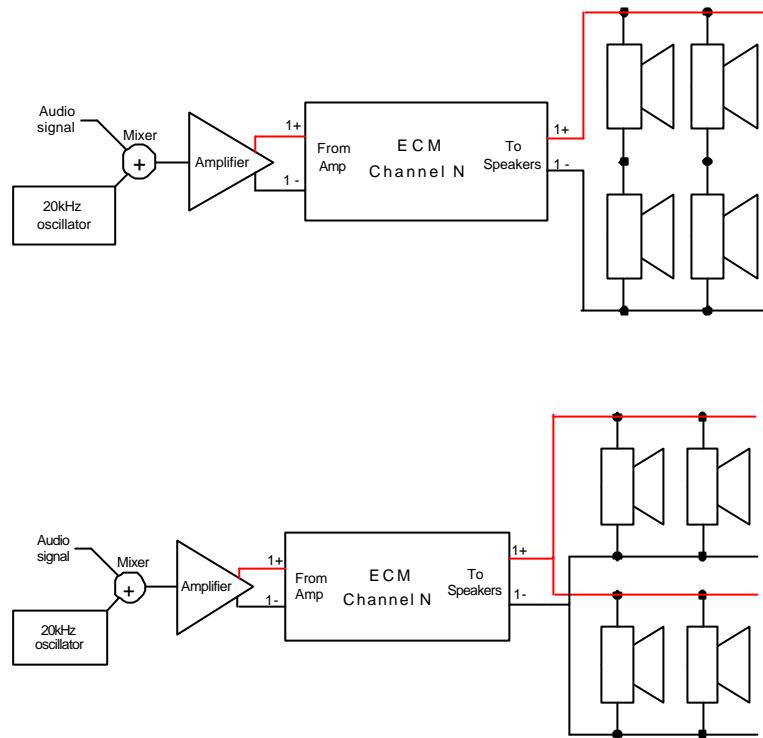

If using this method of monitoring for low level 100V line systems (loading below 30 watts) it is recommended that a EOL terminator is used.

Fault detection

The amplifier output is monitored for :-

1. **Cable fault**, a break in the cable between the detector and speakers. This is detected by signal presence at the power amplifier but the speakers draw no current.
2. **Load fault**, an excessive change in speaker line loading. This is detected when the speaker load changes by more than 20 percent.
3. **Short fault**, a short on the speaker line or a fail power amplifier. This is detected by the absence of signal at the power amplifier.

Audio connections 4 wire system.

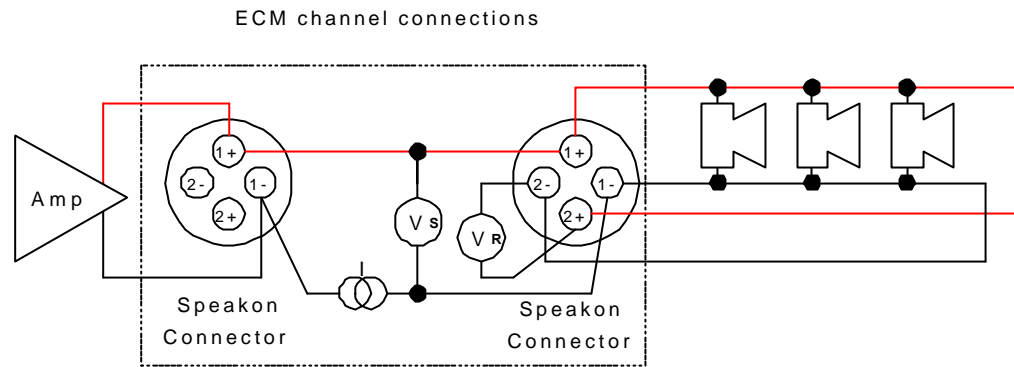

Audio connections 2 wire system.

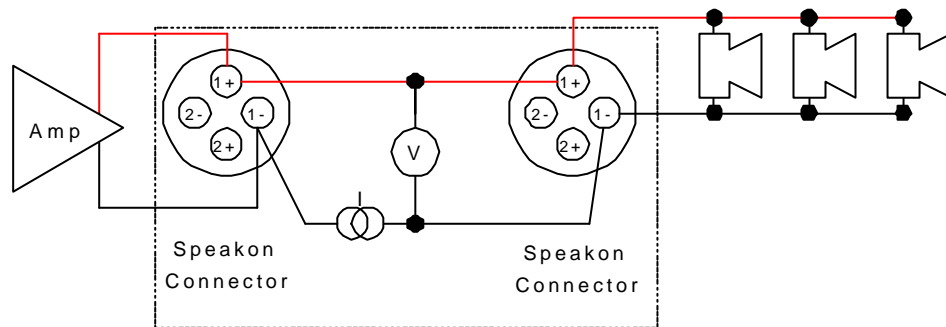

Appendix D

Event Input Description

The ECM has four opto-isolated inputs for monitoring external events. When the ECM is networked to either a SID or JNR (refer to enclosed CD) the events can be registered on an LCD display. All logged faults can then be printed or stored to a log file on a PC.

Configuration

Each fault input can be configured to operate in three modes :-

- ◆ Disabled.

- ◆ Fault when opto off.
Fault reported when opto-coupler diode is un-powered and input OK when powered. This is the recommended mode of operation as a break in the wiring between the contact and the input will be reported as a fault.

- ◆ Fault when opto on.
Inverse of above.

The status of these inputs is not latched, each input can be assigned an individual name for easy fault recognition.

Connectors

Each group of four inputs is provided with a 9-Pin female Dee-type connector.

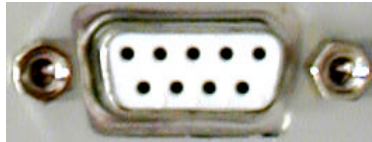

Pin 1 Input 1 +
Pin 2 Input 2 +
Pin 3 Input 3 +
Pin 4 Input 4 +
Pin 5 12V @ 50mA max
Pin 6 Input 1 -
Pin 7 Input 2 -
Pin 8 Input 3 -
Pin 9 Input 4 -
Shell = Gnd

N.B. If the internal supply is to be used to power the inputs, it is essential that a good electrical and mechanical connection be made between the plug and socket shell as this is used as the ground terminal.

Connections

The diagram below shows how a voltage free contact should be wired.

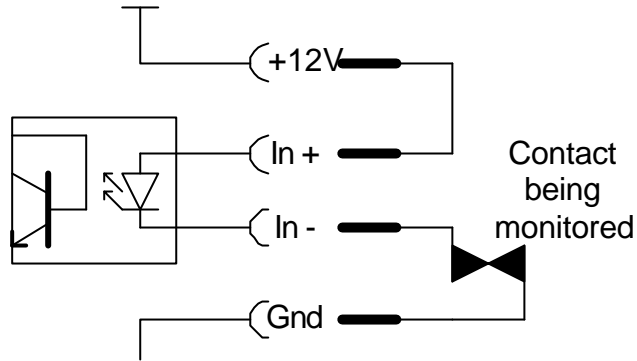

Using an external power supply.

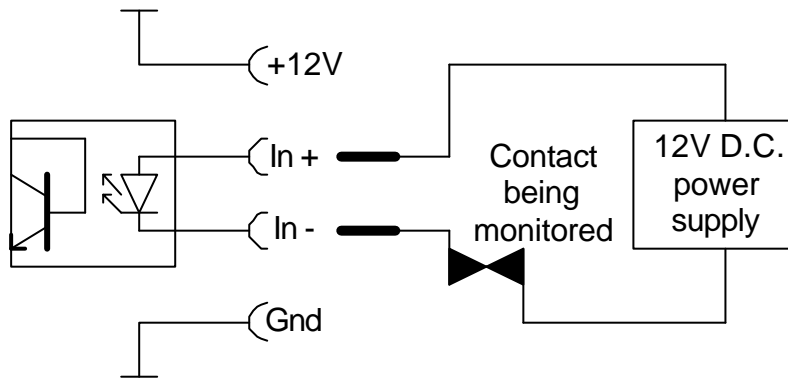

The Opto-diodes can be driven by **active** outputs as shown below

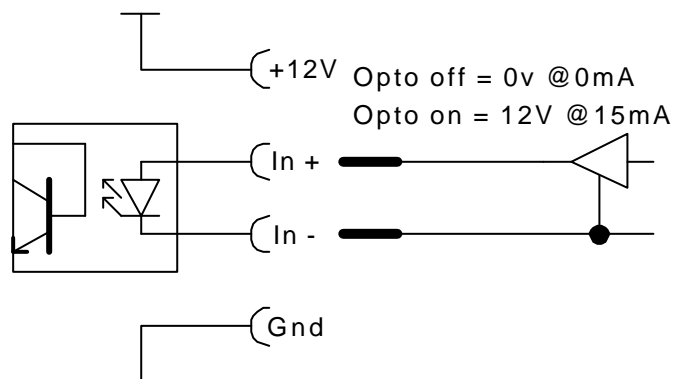

N.B. If an external supply or active drive is used, careful attention must be taken over ground routing.

Appendix E

Common Fault Relay

The common fault relay is activated on detection of any fault. It could be used to enable a sounder or light indicator on detection of a fault, to alert an engineer of a fault on the system.

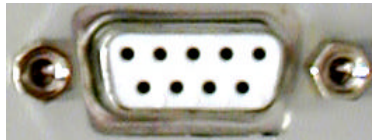

Pin 1 Relay Wiper
Pin 2 NC when not in fault
Pin 3 NO when not in fault
Pin 4-9 No connection
The contacts are rated @ 30V 1A

Power Supply

230V 50Hz, the mains fuse (T500mA 20mm) is mounted within this connector. The fuse carrier also contains a spare fuse. To reduce the risk of fire replace the mains fuse only with the same type.

DC power inlet

There is an optional (24V+/- 1V @ 1A) input provided above the mains input. This can be used instead of the mains or as battery backup should the mains fail. The plug is a standard DC connector with 2.5mm dia, 5.5mm external and 14mm long. The centre pin is positive.

Appendix F

Optical Fibre Connectors

These are ST bayonet connectors operating at a wavelength of 820nm. The fibre length between units should not exceed 2km (with 2 couplers in line, i.e. for patch panels). To achieve the required fault tolerance twin fibres loops are used, these should be routed in physically divergent routes and opposite directions, as shown below.

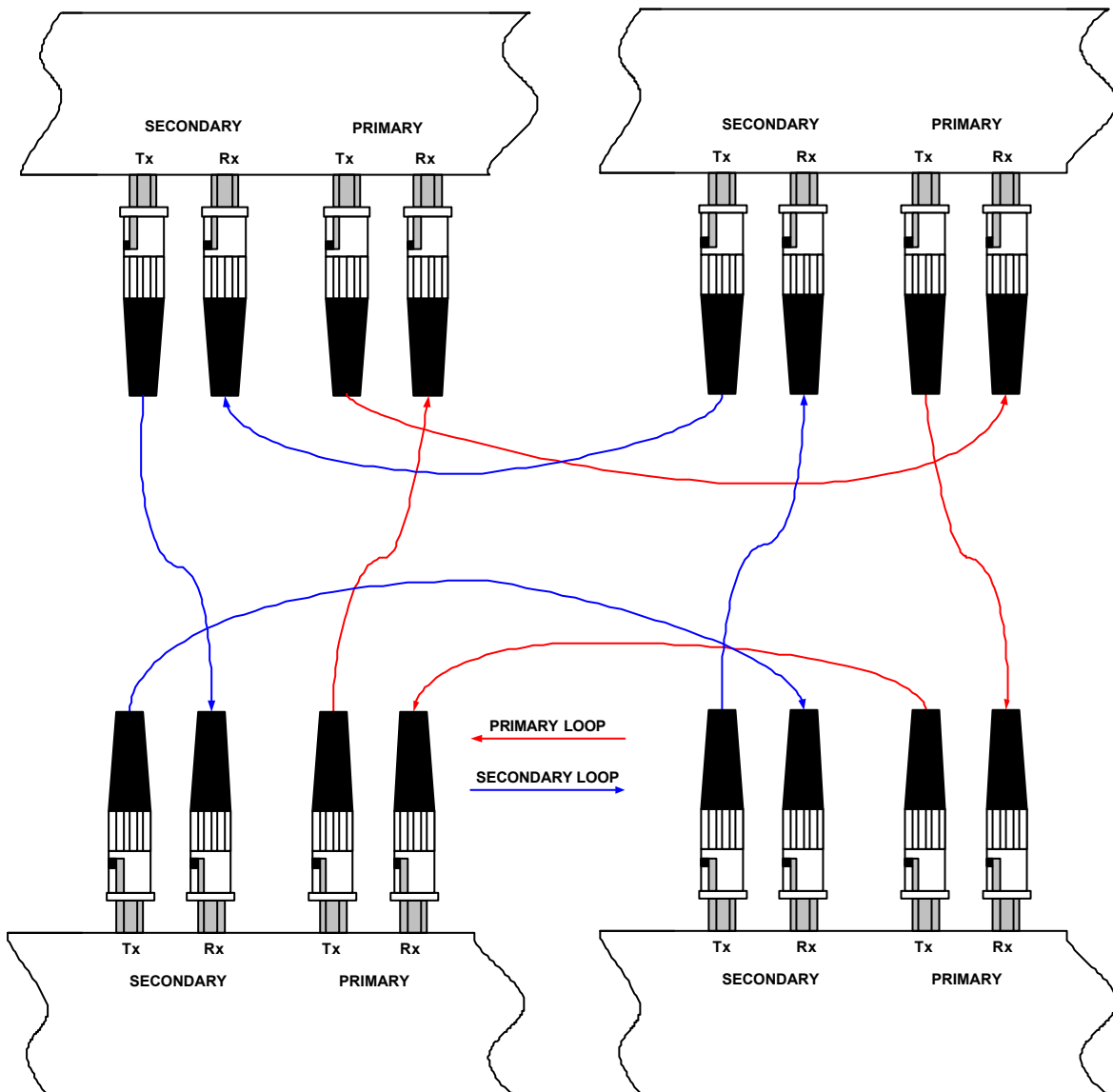

Manufacturers Information

The ECM is manufactured in England by IKON AVS Ltd. Units may be branded IKON AVS or M+D Design.

For service or warranty advice please initially contact your supplier. Alternatively contact the manufactures at:-

IKON AVS Ltd

Unit 238 Ikon Trading Estate
Droitwich Road
Hartlebury
Worcestershire
DY10 4EU

Telephone: (44) 01299 250991

Fax: (44) 01299 250983

Website

www.ikonavs.com

Technical support e-mail:-

support@ikonavs.com

Electromagnetic Compatibility

This equipment has been designed, manufactured and tested to conform to the European EMC directives EN55103-1 & EN55103-2 for classifications E2 and E4.

Limitations as to use:

- 1.** The specified equipment is to be mounted into an earthed, steel equipment rack and not mounted adjacent to RF transmitting or receiving equipment.