



DAI-4

(Digital Audio Interface)

Description

The DAI contains dual 24 Bit A/D and D/A converters with software configurable analogue I/O stages to interface two bi-directional audio channels onto a pair of fibre optics. For critical systems the use of dual redundant fibres is included as is the injection and verification of surveillance signals.

Simultaneous monitoring, control & serial data channels are embedded allowing a comprehensive digital interface & distribution system to be easily implemented



CONFIGURATION & OPERATING MANUAL

Contents

DESCRIPTION	1
CONNECTING THE DAI.....	3
FRONT PANEL CONTROLS	4
AUDIO LEVEL INDICATION	4
STATUS INDICATION	4
DAI SOFTWARE	5
USER INSTRUCTIONS	5
SYSTEM CONNECTIONS AND CONFIGURATION	5
<i>Control Tab</i>	5
<i>Input Tab</i>	6
<i>Configuration Tab</i>	6
<i>Monitoring Tab</i>	10
<i>Routing Tab</i>	10
<i>File Menu</i>	11
INPUT & OUTPUT LEVELS	11
CONFIGURATION.....	12
MONITORING	13
<i>Error Count</i>	13
APPLICATIONS	14
APP1:- POINT TO POINT AUDIO.....	14
APP2:- POINT TO POINT AUDIO AND EMBEDDED RS232	15
APP3:- MULTIPLE PAGING STATIONS WITH REDUNDANT LINK	16
APP4:- RING NETWORK WITH SELECTIVE PAGING	17
APPENDIX A	19
INTERNAL BLOCK DIAGRAM.....	19
APPENDIX B	20
CURRENT CONSUMPTIONS	20
APPENDIX C	21
AUDIO CONNECTIONS.....	21
- = COLD (ANTI-PHASE)	21
DATA I/O.....	22
RS PORT	24
FAULT OUTPUTS.....	25
CONFIGURATION PORT	25
FRONT PANEL INDICATORS	26
MAINS POWER INLET.....	26
D.C. POWER INLET.....	26
APPENDIX D	27
OPTICAL FIBRE CONNECTORS.....	27
OPTICAL FIBRE REQUIREMENTS.....	28
MANUFACTURERS INFORMATION	29

Connecting the DAI



Refer to Appendix C for connector pin-outs.

- Audio In** Two separate balanced audio line inputs on detachable 3.5mm screw terminals. Separate programmable Level is included for each input
- Audio Out** Two separate balanced line level outputs on detachable screw terminals with power on muting and individual Level control. An option board provides an adjustable 20KHz surveillance tone can be mixed with the program audio for use with external fault monitoring systems
- Transmit** Twin (Primary & Secondary) ST fibre connectors for the outgoing fibre connections to other elements of the system. Each output carries the same audio information but separate control data to allow automatic fibre network verification & tests. The system is software configurable for single or dual fibre operation.
- Receive** Twin (Primary & Secondary) ST fibre connectors for the incoming fibre connections from other elements of the system. The system is software configurable for single or dual fibre operation with correct operation verified and reported.
- Control** A multifunction port allowing the connection of:-
1. PTT push button for page access,
 2. Control keypad for selection of paging zones,
 3. Outputs to remote amplifier page access,
 4. Outputs to remote routing matrix,
- RS232 / RS422 / RS485** Transparent serial data for communications and control available as RS232, RS422 or RS485. You can use the DAI to carry out format conversion between units.
- Status** For connection to external fault monitoring systems. The port carries four configurable status lines to verify the operation status of the fibre network and power supplies,
- Power** Dual power inputs are provided from both mains and 24V DC. The status of both can be monitored and any deviation from normal operation flagged as a fault.

Front Panel Controls

There are no user controls on the DAI-4 only indicators and the programming port.

Audio Level Indication



The input levels are an indication of the level into the unit and are not adjusted with the internal software controlled attenuators.

The bottom led is a signal presence indication set for -35dB .

Ensure that the input is adjusted from the source not to exceed $+6\text{dB}$.

Output levels represent the actual level from the unit and are adjusted with the software controlled output attenuators. A -35dB signal presence indicator is also incorporated.

Status Indication



Network Status The four LED's on the front panel provide indication of the DAI's operation. The Primary/Secondary RX LED's will be illuminated when a valid signal is being received on the appropriate fibre. The Primary/Secondary TX LED's will be illuminated continuously when the DAI's is transmitting normal data. The TX LED's will flash if they are transmitting data from the other fibre when using dual fibres and one of the fibres has failed.

Program Used to configure the DAI using the software provided.

DAI Software

User Instructions

System connections and configuration

Configuration of the DAI's is via the DAI Control utility. This will operate on a PC running Windows 2000 or XP with Internet Explorer 6.0 or newer. An unused RS232 port or USB port with adapter is required and this is connected to the 9 pin D connector on the DAI front panel for configuration only. It is not required for operation.

Control Tab

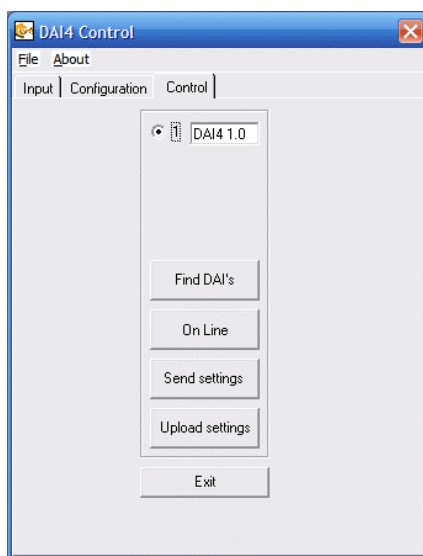

At start up only the "Find DAI's" button will be visible.

Click Find DAI to locate DAI's connected to the PC. A list of DAI's found will appear. Select the appropriate DAI to configure. "Send Settings" and "Upload settings" will appear.

Clicking "Send settings" will transfer the settings from the utility to the DAI. THESE SETTINGS WILL BE THE RESTORED WHENEVER THE DAI IS POWERED UP.

Clicking "Upload settings" will transfer the power up settings from the DAI to the utility.

If the configuration of the DAI is the same as the settings within the utility the "On-line" button will appear. If the "On-line" button is not visible either send or upload the setting to/from the DAI as appropriate. When On-line changing settings in the utility will be immediately transferred to the DAI. ANY CHANGES MADE WHEN ON LINE WILL BE LOST WHEN THE DAI IS POWERED OFF.

Clicking "Exit" will terminate the utility.

Input Tab

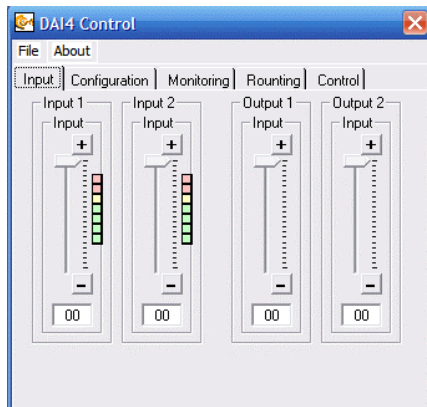

The input tap gives access to the two input and output level controls.

Click the “+” or “-“ buttons to change settings.

The input “level meters” only appear when the DAI is online and are an approximation of the peak level prior to the A/D converters.

Configuration Tab

Fibre connections

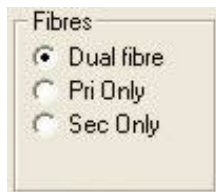

This section defines how the fibre network is configured.

The following demonstrates connections and configuration for possible operating modes of a DAI system. In these the left hand unit is the master of the system, i.e. the master link on the Data I/O connected is made.

(A) Primary fibre only (Non Looped)

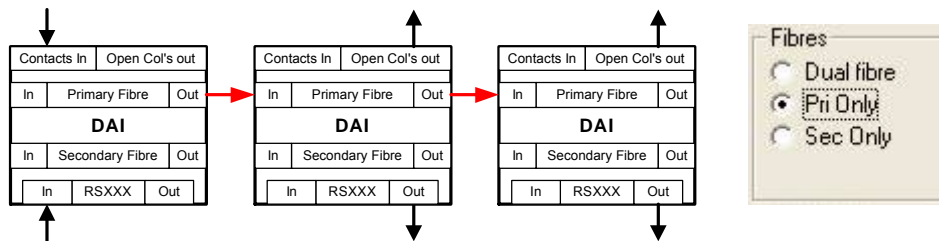

Master is input for audio, contacts and serial. All other units are output only. Fibres are not fault tolerant.

(B) Primary fibre only (Looped)

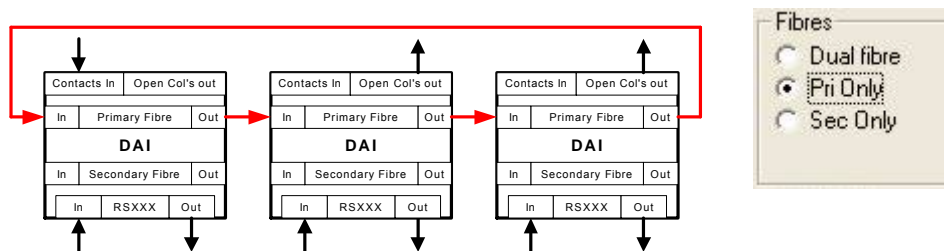

Master is input for audio and contacts. Serial can be bi-directional to/from each unit. Fibres are not fault tolerant.

(C) Secondary fibre only (Non Looped)

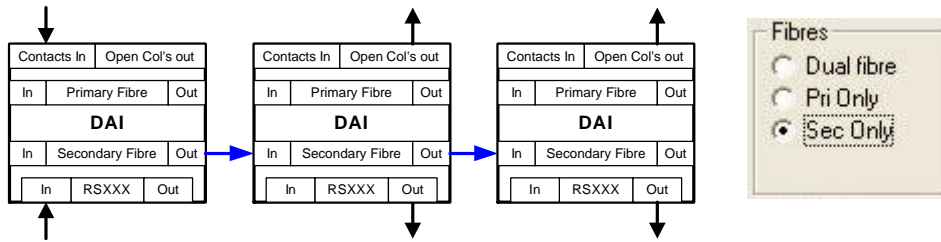

Master is input for audio, contacts and serial. All other units are output only. All other units are output only. Fibres are not fault tolerant.

(D) Secondary fibre only (Looped)

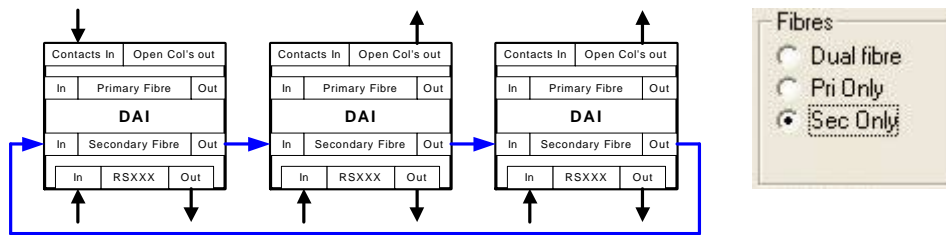

Master is input for audio and contacts. Serial can be bi-directional to/from each unit. Fibres are not fault tolerant.

(E) Dual fibre not-looped

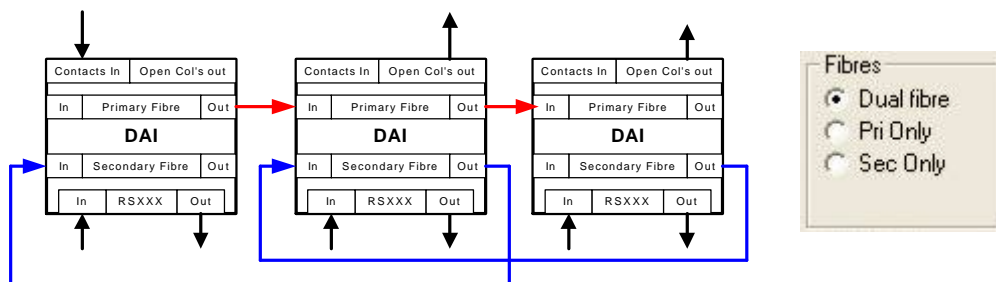

Master is input for audio and contacts. Serial can be bi-directional to/from each unit. Fibres are not fault tolerant.

(F) Dual fibre looped

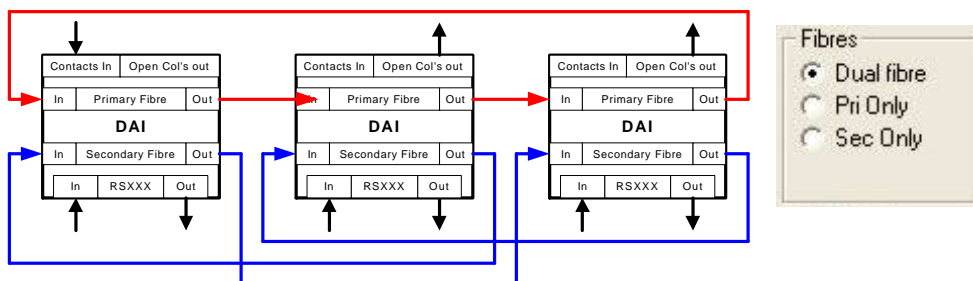

Master is input for audio and contacts. Serial can be bi-directional to/from each unit. Fibres are fault tolerant.

Two Units can be used back to back to provide a simple means of transferring audio, contacts and serial in both directions. In these modes BOTH units have their master link made

Unit Number

Unit number options control how the units interact on the system

(A) Global operation

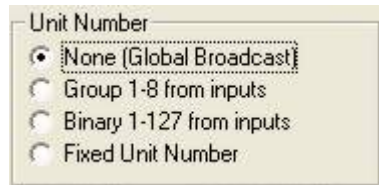

In this mode the system comprises a master and one or more “slave” units. All contacts states and serial message go from the master unit to ALL other DAI units on the system. Push to talk and serial filtering are not available. Serial from the slave units is not available in this mode.

(B) Group operation

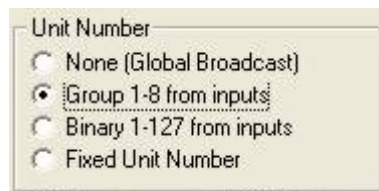

In this mode the select inputs are used to define/ select one or more of eight “groups”. All contacts states and serial message go from the master unit to ALL other DAI units on the system. Push to talk and serial filtering are available. Serial from the slave units is not available in this mode.

(C) Binary 1-127 from inputs operation

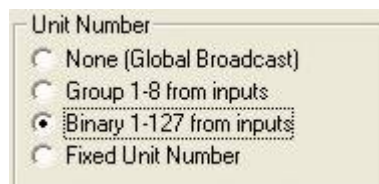

In this mode the select inputs are used to define/ select a binary unit number from 1 to 127. Address 0 is always used by the master. All contacts states and serial message go from the master unit to ALL the other DAI units on the system. Push to talk and serial filtering are available. Serial from the slave units is available in this mode. To use serial from the slave units each unit on the system must have a unique address.

(D) Fixed unit number

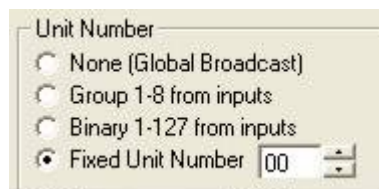

This is similar to the Binary mode but the select inputs are ignored and the address defined in the utility is used instead.

Push to talk controls



The push to talk input delay is only used on the master unit and is intended to allow time for external contacts connected to select input to settle before the push to talk active message is sent to other units on the system.

The push to talk output delay provides a delay between slave unit receiving the push to talk active message from the master unit and its push to talk output becoming active. This can be used to provide a delay for external decoding equipment to react.

The push to talk output can be set to “Global” which means that it will always follow the master DAI irrespective of the slave units select input; or it can be filtered in which case the slave units select inputs must match the master’s inputs before the push to talk output is actuated.

RSXXX comms

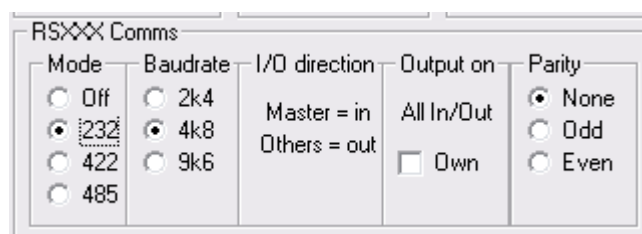

These settings control how the RSXXX port operates. Mode, parity, baud rate, I/O direction and select the basic operation of the port. When output on is set to “All” all slave units will output serial data irrespective of the push to talk state of the unit. If set to filtered, serial data is only outputted if the units push to talk output is active. The own option is only available when units are operating on a fibre loop. When selected a unit will echo back any serial input after it has been passed completely round the fibre loop.

Error reporting

Selects which fault(s) appear on which fault output. They are

Error reporting	Out 1	Out 2	Out 3	Out 4
Pri Fibre/AES Fail	<input checked="" type="checkbox"/>	<input type="checkbox"/>	<input type="checkbox"/>	<input type="checkbox"/>
Sec Fibre/AES Fail	<input type="checkbox"/>	<input checked="" type="checkbox"/>	<input type="checkbox"/>	<input type="checkbox"/>
Mains Supply Fail	<input type="checkbox"/>	<input type="checkbox"/>	<input checked="" type="checkbox"/>	<input type="checkbox"/>
24V Supply Fail	<input type="checkbox"/>	<input type="checkbox"/>	<input type="checkbox"/>	<input checked="" type="checkbox"/>

1. Pri Fibre/AES fail = the primary input fibre or receiving electronics has failed.
2. Sec Fibre/AES fail = the secondary input fibre or receiving electronics has failed.
3. The 240V mains supply has failed
4. The D.C. supply input has failed.

Any selected fault occurring will cause the appropriate fault output to go off.

Monitoring Tab

This tab is only available when the DAI is on line. Displays are provided for

Internal level at the DAI's A/D converters.

The error counts section displays the internal fault counts, which may be used to identify system problems.

Current error states

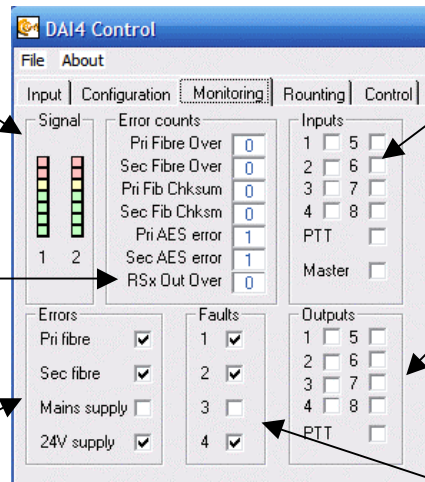

Inputs
Shows the active status of any control inputs into the DAI.

Outputs
Shows the active status of the DAI's control outputs as received from via the fibres.

Status of the fault outputs.

Routing Tab

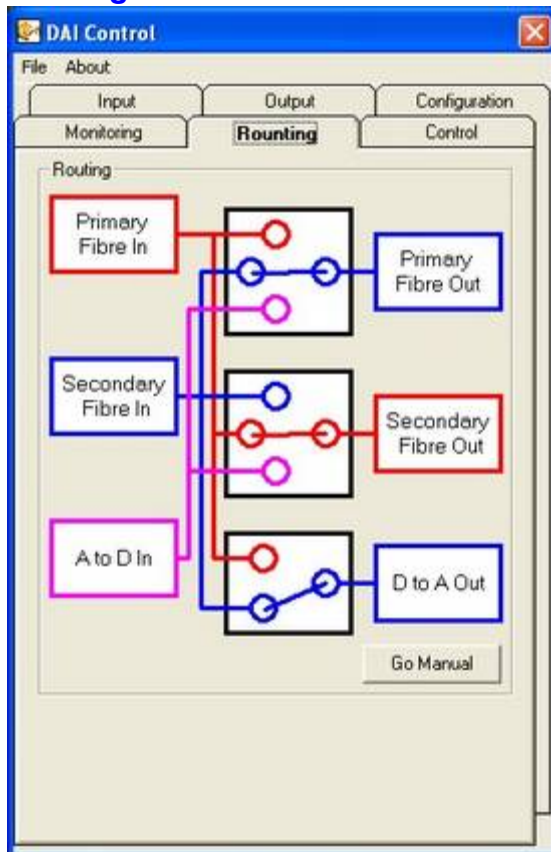

This tab is only available when the DAI is on line.

Normally this tab indicates how the internal routing of the DAI is operating. Clicking on "Go manual" allows the utility to directly control the units routing. When on manual control clicking on the change button above each switch will step that switch onto its next setting. Clicking on "Go Auto" will return the DAI to automatic routing. Manual routing control is only provided for testing and is not remembered by the DAI.

File Menu

New	=	Reset all setting to default.
Open	=	Open an existing DAI file
Save	=	Save settings to current DAI file
Save As	=	Save settings to a new file
0: to 3:	=	List of previously used files
Exit	=	Close utility
About	=	Display utility information.

Input & Output Levels

The input meters are only available when on line.

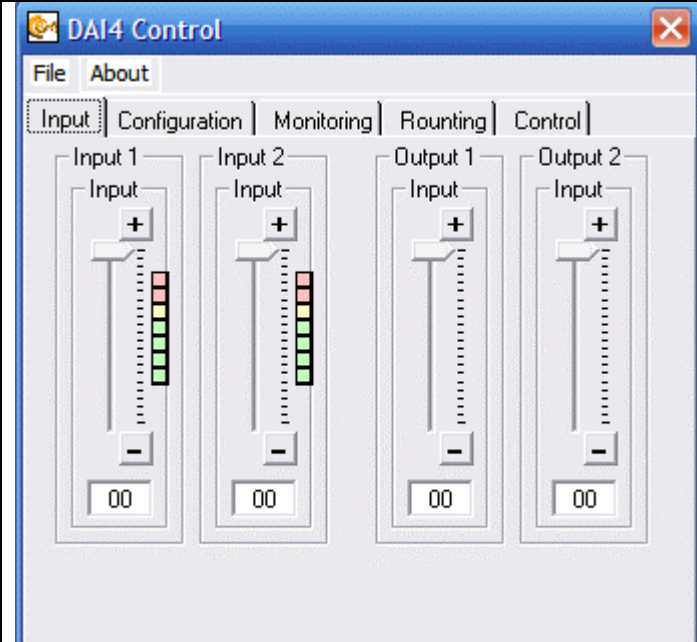

The screenshot shows the 'DAI4 Control' window with a menu bar (File, About) and a tabbed interface (Input, Configuration, Monitoring, Routing, Control). The 'Input' tab is active, displaying four vertical level meters: Input 1, Input 2, Output 1, and Output 2. Each meter has a '+' button at the top, a '-' button at the bottom, and a digital display at the bottom showing '00'. The meters are currently at the 00 level, with the top of the scale in the red zone. The Input 1 and Input 2 meters have a red bar at the top, indicating an overload.

Input Level
Adjust so that the software meters are not entering the red zone as this indicates an overload of the A/D converters.
Range = 0dBu to -63dBu

Output Level
0dBu to -63dBu
Adjust to match attached equipment input level.

Configuration

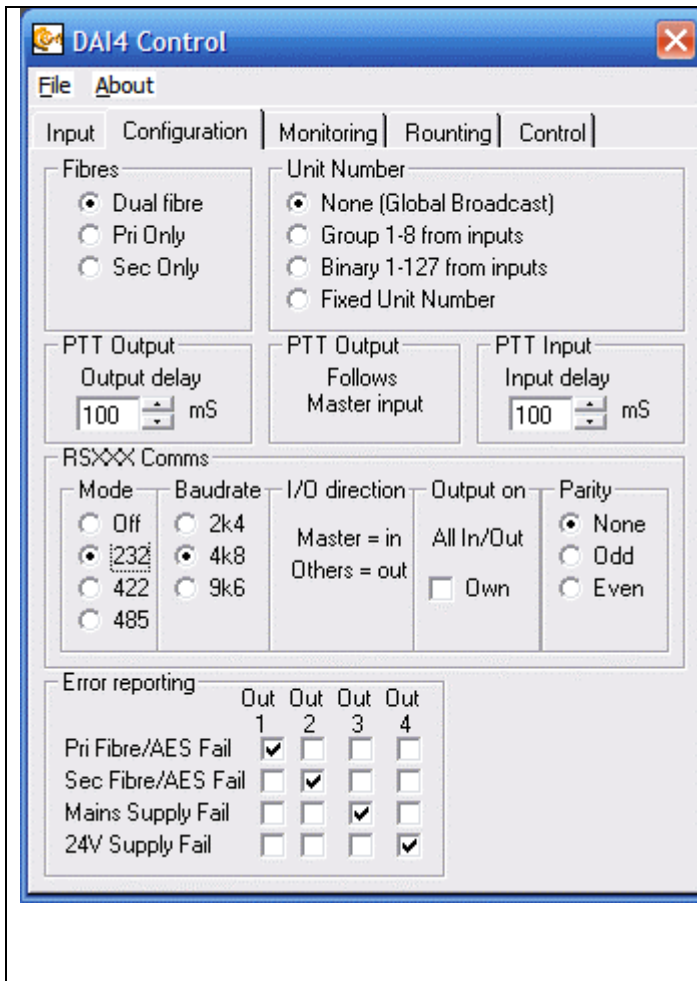

Fibres

Set for Dual or single fibres

Unit Number

Set mode of DAI operation in the system.

Push To Talk settings

Set time delays to allow external hardware to settle and decoding of the PTT outputs on slave units.

RSXXX comms

Define the operation of the auxiliary serial port.

Error Reporting

Controls which output the error message is sent to on the STATUS "D" connector.

Errors are reported to the status output when ticked.

Monitoring

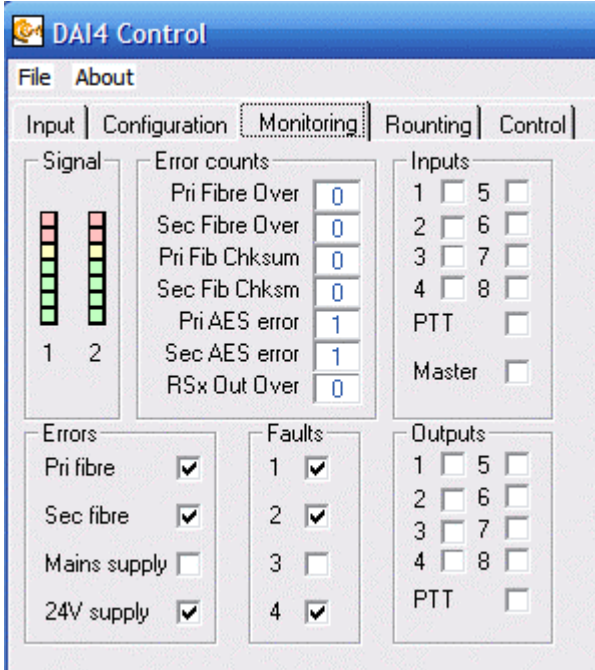
 <p>The screenshot shows the 'DAI4 Control' software window with the 'Monitoring' tab selected. It features several sections: 'Signal' with two vertical bar indicators; 'Error counts' with numerical values for various error types; 'Errors' with checkboxes for 'Pri fibre', 'Sec fibre', 'Mains supply', and '24V supply'; 'Faults' with checkboxes for 1, 2, 3, and 4; 'Inputs' with checkboxes for 1-8 and 'PTT', 'Master'; and 'Outputs' with checkboxes for 1-8 and 'PTT'.</p>	<p>Signal Displays current signal levels at the A/D converter.</p> <p>Errors Display the current internal error states</p> <p>Error count Internal error counters. For use by Ikon personnel.</p> <p>Inputs Displays the current states of the input contacts. Ticked = link on.</p> <p>Outputs Displays the current output states. Ticked = on.</p> <p>Faults Displays the current fault output states. Ticked = OFF.</p>
---	---

Error Count

Whilst a single primary or secondary AES error can be expected when the units are first powered and the ring established, continuous errors are generally an indication of a faulty fibre or miss connected network (i.e. a primary and secondary crossed somewhere).

Applications

App1:- Point to point audio

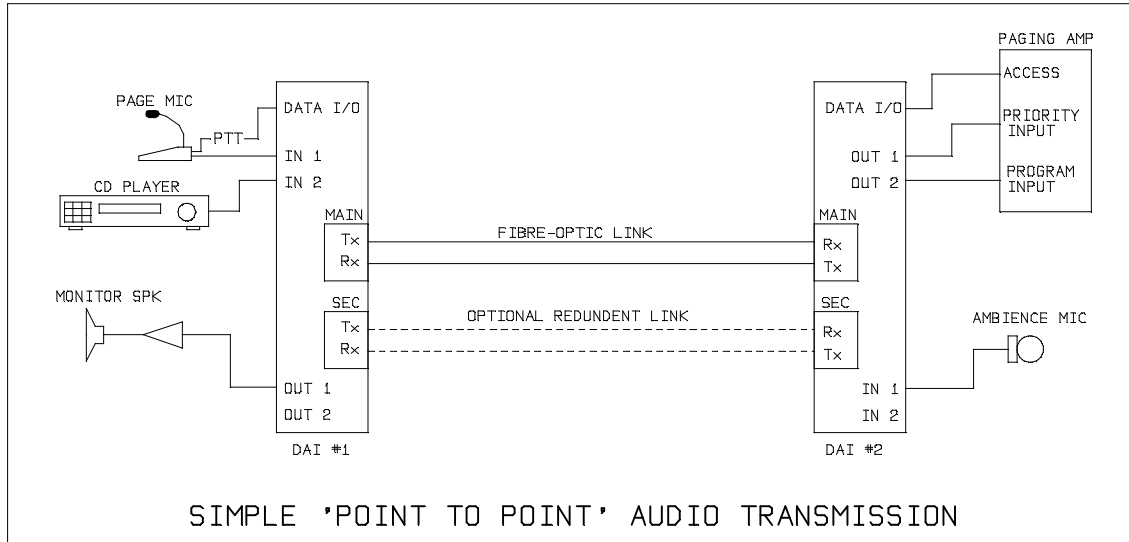

In the above application a simple two station paging system is shown.

Input 1 of DAI #1 is configured for microphone operation and is used to carry the paging microphone. Input 2 is used to carry background music from a CD although this can be any line level source. DAI #2 is the remote receiver with its two line outputs feeding two inputs of a paging amplifier. Output 2 is used to carry background program signals to the paging amplifier whilst Output 1 is used to feed the priority channel that can either use VOX switching or more commonly a PTT status signal carried from DAI #1.

The return audio from DAI #2 back to DAI #1 is, in this application, used to provide the operator with a feed of ambience from the output zone. In reality the monitor speaker would be via a muting relay linked to the PTT on the microphone to mute the speaker when a page is in progress. A suitable output for this is provided on the DAI's control port.

The two return audio paths can be used for any purpose or dispensed with altogether allowing the lower mauve fibre to be eliminated unless status telemetry from DAI #2 is required for monitoring purposes.

In life safety and similar critical systems the use of the second redundant fibres is recommended.

App2:- Point to point audio and embedded Rs232

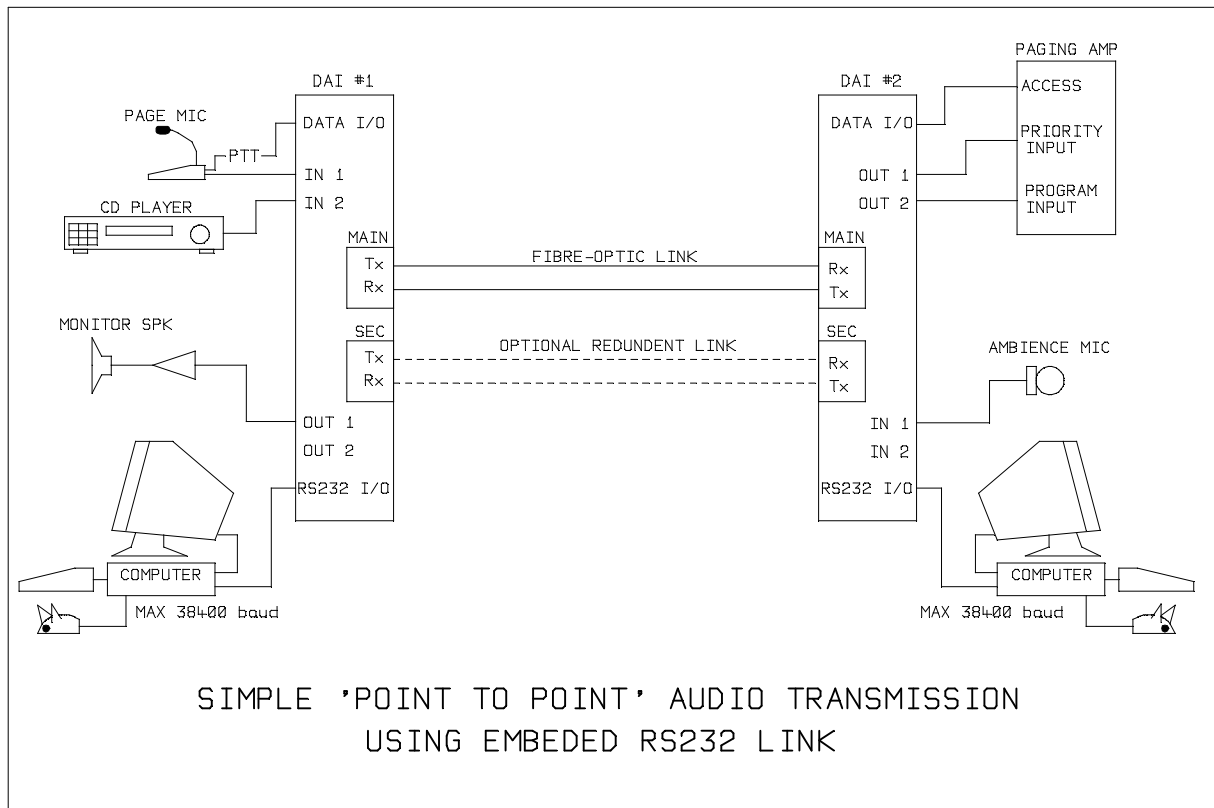

This application is identical to Application 1 but with the transparent data channel utilised.

This data channel, accessible from the Control port, provided a three wire RS232 interface between units. (5 wire RS422 available to order).

In a point-to-point system a computer or any other RS232 device running at any data rate to a maximum of 38,400 baud can be connected to allow a transparent transfer of data between two DAI's. For by-directional communications both primary fibres must be used.

In a ring topology (see application 4) data can also be carried. It originates at the Master DAI and loops at each intermediate DAI but is buffered to provide a RS232 output for control functions.

App3:- Multiple paging stations with redundant link

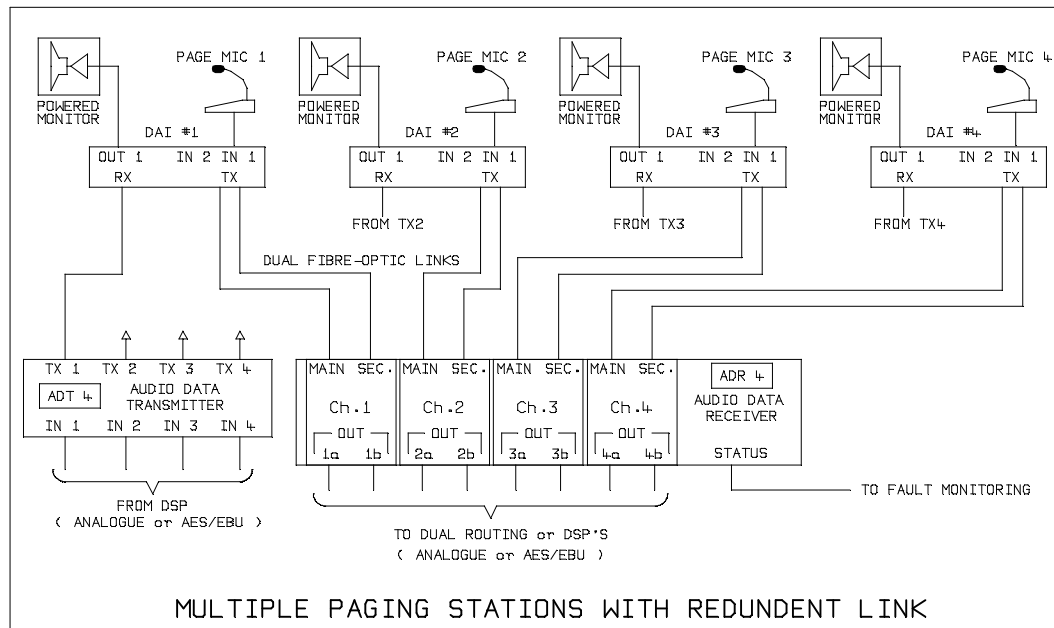

Application 3 is typical of a life safety system as used in Sports Venues, Exhibition Centres etc..

The DAI units are used to provide a monitored paging microphone and confidence monitor. The microphone is linked to a dedicated Audio Data Receiver (Ikon AVS model ADR4). Both the Primary & Secondary links from the DAI's are monitored as well as the remote DAI's status. Any faults are reported to the fault monitoring system via the ADR4. Whilst not show on the diagram, control data can be carried from the DAI's and independently accessed at the ADR4's control port.

The ADR4 provides two identical but buffered outputs of each incoming paging microphone designed to feed dual signal processing & routing systems. Two variants are available for the ADR4, one providing balanced line analogue audio (ADR4-A) and a second providing Digital outputs in AES/EBU format (ADR4-D).

Return audio data to the remote DAI's is generated in the Ikon AVS ADT4. As with the ADR4, two variants are available, ADT4-A analogue audio to fibre transmitter and the ADT4-D, AES/EBU to fibre transmitter.

App4:- Ring network with selective paging

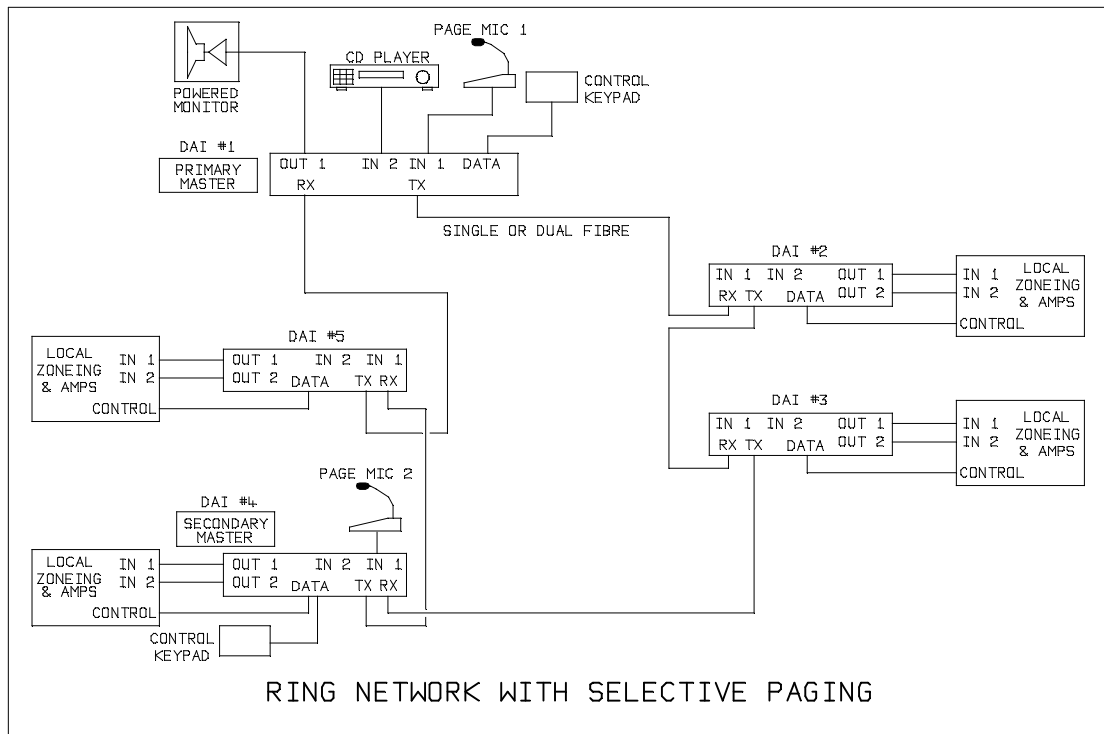

The DAI's can be configured for operation as a simple ring system to provide a twin channel distributed audio & paging system. Normally a designated master station would originate both background music and paging information. Audio channel 2 (from input 2) would be distributed to all remote DAI's where it is fed into the non-priority input of paging amplifiers, routing matrixes etc.. The remote DAI's would be software configured to received incoming data and re-transmit the same data to the next node.

Audio Channel 1 (input 1) would be the paging microphone. In addition to the usual PTT push button a keypad would be included allowing selected zone(s) to be accessed. The remote DAI's would be similarly configured each with a unique zone code within the system.

The system supports dual fibre ring operation and can also support a Secondary Master DAI that can control the system in the event of a failure in the Primary Master DAI. The primary master will always take priority.

In the above example the primary master DAI is shown only with a monitor loudspeaker, this could be a full paging amplifier or similar as per the remote DAI's.

Full Status monitoring is available and can be accessed at each DAI for inclusion into a separate fault monitoring network.

The ring network also allows the use of the RS232 (or RS422) auxiliary data channel running at any data rate to a maximum of 38,400 baud.

The system can be configured in two modes:-

Loop Mode

The default for ring operation allowing a RS232 data originating device to be connected at the Primary Master DAI with the transmitted data appearing at each remote DAI as a buffered RS232 output only. Normally used for control over serial routing matrixes or similar this expands the control access for remote zones allowing the remote matrix to sub zone & route the two audio channels.

Through Mode

At each DAI the incoming data is fed into an external RS232 device for processing and control. The external device will, after appropriate processing, send RS232 data onto the next DAI and associated RS232 device.

A combination of both methods is possible as would be required if a two master system was to be used.

The user RS232 data is carried around the ring on the same fibres as the audio and is in addition to any control and status monitoring data.

Appendix A

Internal block diagram

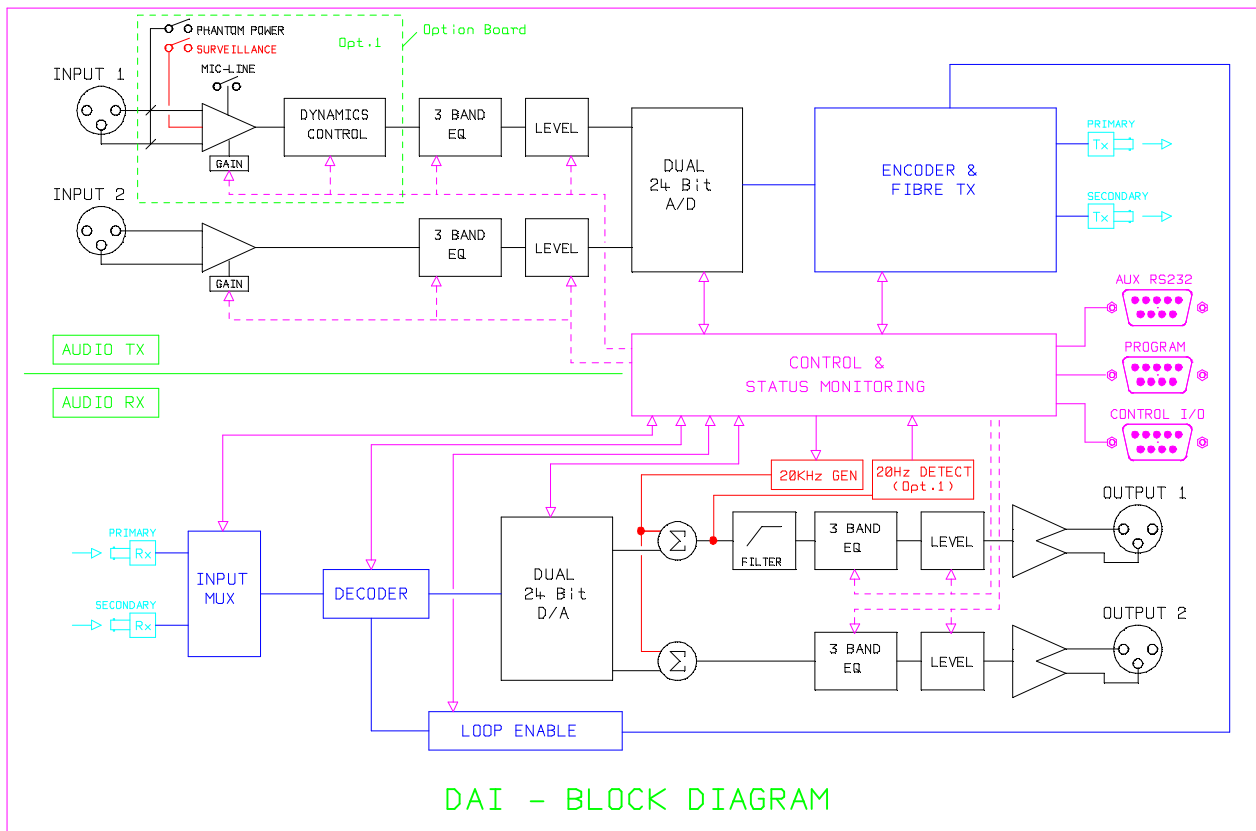

Engineering Specification

	Analogue Input 1	Analogue Input 2
Type	Electronic Balanced	Electronic balanced
Impedance	10K ohms	10K ohms
Sensitivity	Line: -10dB to +10dB	Line: -10dB to +10dB
Phantom Power	+24V	-
Max input level	+12dB	+12dB
Attenuation Range	0dB to -62dB in 1dB steps and Mute	0dB to -62dB in 1dB steps and Mute

Outputs	Digital Audio Processing	Overall
Type: Electronic Balanced	A/D: 24 bit 64x oversampling	Freq. Resp.: 20Hz to 20KHz +/- 1dB
Impedance: 150 ohms	D/A: 24 bit 8 x oversampling	THD + Noise: < 0.05%
Max Level: +10dBu	Sample Freq.: 48KHz	S/N Ratio: Better than 98dB A Weighted.
Level Range: As Inputs		

Appendix B

Current consumptions

Mains Operation

Quiescent current 45mA
Inrush current 450mA

Mains Fuse = T500mA, 250V

24V DC Operation

Quiescent current 500mA
Inrush current >1.2A

Appendix C

Audio Connections

Analogue Inputs

Dual analogue line level inputs are connected as

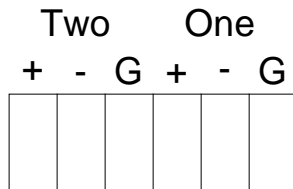

G = Ground

+ = Hot (Phase)

- = Cold (Anti-Phase)

Analogue Outputs

The two analogue balanced outputs are connected as

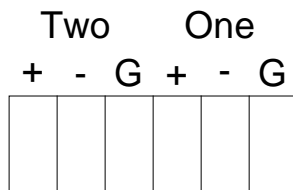

G = Ground

+ = Hot (Phase)

- = Cold (Anti-Phase)

Data I/O

Simple data connections to support selective paging and channel routing are incorporated accessible for the Control Port.

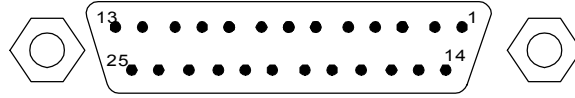

25W 'D' Remote Socket	Description	Comment
1	In 0	For use with external push buttons etc. Link to 0V to activate.
2	In 1	as above
3	In 2	as above
4	In 3	as above
5	In 4	as above
6	In 5	as above
7	In 6	as above
8	In 7	as above
9	In PTT	as above
10	Master	Link to 0V on master unit only.
11		
12	0V	
13	0V	
14	Out 0	Open Collector <30v 100ma
15	Out 1	Open Collector <30v 100ma
16	Out 2	Open Collector <30v 100ma
17	Out 3	Open Collector <30v 100ma
18	Out 4	Open Collector <30v 100ma
19	Out 5	Open Collector <30v 100ma
20	Out 6	Open Collector <30v 100ma
21	Out 7	Open Collector <30v 100ma
22	Out PTT	Open Collector <30v 100ma
23		
24	+12V DC	
25	+12V DC	

All inputs are designed to 'pulled down' to 0V via an electrically isolated contact.

All outputs are open collectors.

A DAI is defined as the system master when then the Master Input is grounded, if it is left open the unit operates as a Slave. The Master Input is tested during power up; it is ignored the rest of the time.

The select inputs can be used in three ways

1. Digital inputs, which are mirrored on all other units in the system.
2. Group inputs, used in conjunction with push to talk filtering. Each slave unit is programmed a member of eight groups, i.e. if input 1 is grounded it is a member of group 1, if 2 than a member of group 2 etc. A slave can be a member of more than one group. The select inputs on the master unit then define which group is active when the push to talk input is activated. I.e. if input 1 is active on the master when its push to talk input is activated will activate the push to talk output on all slave units whit input 1 activated. Multiple inputs on can be activated at the same time to select several groups at the same time.
3. Binary inputs. This is similar to the group mode but the first 7 inputs are used to provide a binary unit address both for the slave and master units. Only one slave can be selected at any time.

The “push to talk” input is only monitored on a master DAI. It’s state is transferred to the “push to talk” outputs on the other units in the system. Operation of the push to talk output can be configured to operate globally, i.e. follows the master input, or filtered in which case it will only actuate when a specific DAI is selected using the select inputs. Configurable delays are available on both for the push to talk inputs and outputs, to allow contacts to settle.

The select outputs on all units follow the states of the master DAI select inputs.

RS Port

This port provides a serial data channel, it can be configured to RS232, RS422 or RS485 levels with baud rates of 4800, 9600 or 19,200, which is carried transparently over the same network as the audio.

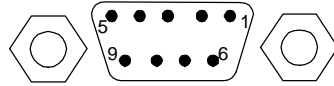

9 Pin 'D' RS232	Description	Comment
1		
2	Tx	Data from DAI to external equipment
3	Rx	Data from external equipment to DAI
4		
5	Signal Screen	
6		
7		
8		
9		

9 Pin 'D' RS422	Description	Comment
1		
2	Tx A (Y)	Data from DAI to external equipment
3	Rx A (Y)	Data from external equipment to DAI
4		
5	Signal Screen	
6		
7	Tx B (Z)	Data from DAI to external equipment
8	Rx B (Z)	Data from external equipment to DAI
9		

9 Pin 'D' RS485	Description	Comment
1		
2	A (Y)	Link to pin 3
3	A (Y)	Link to pin 2
4		
5	Signal Screen	
6		
7	B (Z)	Link to pin 8
8	B (Z)	Link to pin 7
9		

Fault outputs

These provide four open collector outputs that can be used to signal various fault conditions detected by the DAI

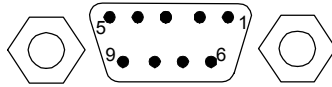

9 Pin 'D' Status Output	Description	Comment
1	Connected to 2,3,4,5	
2	Connected to 1,3,4,5	
3	Connected to 1,2,4,5	
4	Connected to 1,2,3,5	
5	Connected to 1,2,3,4	
6	Open collector O/P status 1	100ma current sink
7	Open collector O/P status 2	100ma current sink
8	Open collector O/P status 3	100ma current sink
9	Open collector O/P status 4	100ma current sink

All outputs are open collectors and are normally on when no faults are present.

The Status Output is designed to fit into a DRS input socket on Ikon AVS fault monitoring system products.

Configuration port

This is a standard RS232 port brought out on a 9 pin Dee connector on the front panel, it is used to configure the DAI's operation.

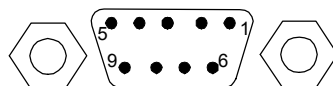

PC End

Female 9 way D

Pin 2

Pin 3

Pin 5

-

-

-

DAI End

Male 9 way D

Pin 2 Tx

Pin 3 Rx

Pin 5 Ground

Front Panel indicators

Four LED's on the front panel provide indication of the DAI's operation. The Primary/Secondary RX LED's will be illuminated when a valid signal is being received on the appropriate fibre. The Primary/Secondary TX LED's will be illuminated continuously when the DAI's is transmitting normal data. The TX LED's will flash if they are transmitting data from the other fibre when using dual fibres and one of the fibres has failed.

Mains Power inlet.

This requires 240V 50Hz. The station's mains fuse (T500mA 20mm) is mounted adjacent to this connector.

The status of the mains input can be included in the fault monitoring.

D.C. power inlet.

In the case of a mains supply failure the supply (24V \pm 1V @1A) provided via this connector will be used instead. The plug is a standard D.C. connector with 2.5mm internal diameter, 5.5mm external and 14mm long. The central pin is the positive connection. The status of the D.C. input can be included in the fault monitoring.

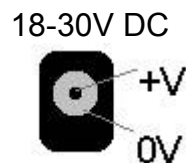

Appendix D

Optical Fibre Connectors

These are ST bayonet connectors operating at a wavelength of 820nm. The fibre length between units should not exceed 2km (with 2 couplers in line, i.e. for patch panels). To achieve the required fault tolerance twin fibres loops are used, these should be routed in physically divergent routes and opposite directions, as shown below.

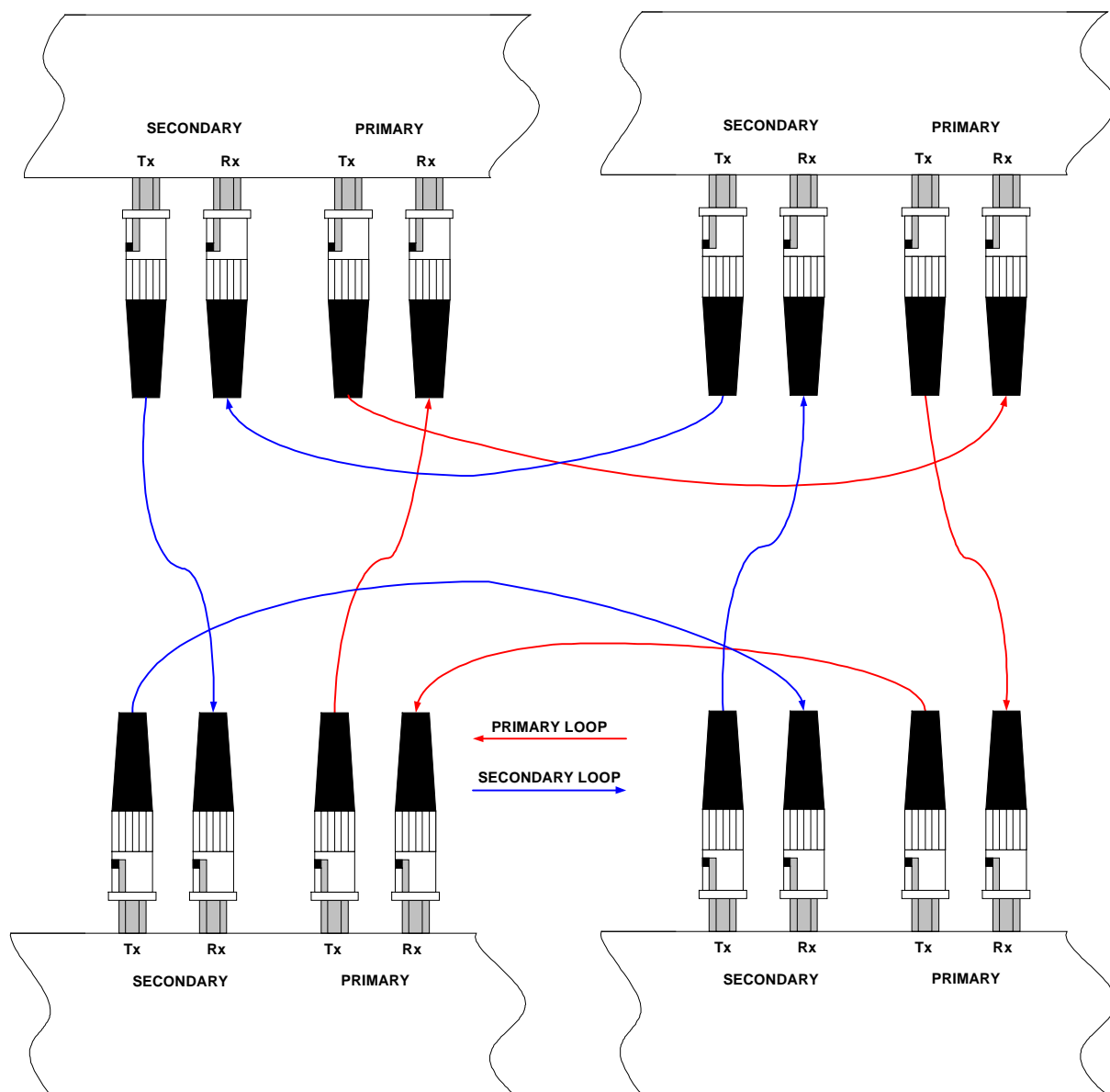

Optical Fibre Requirements

Use either 50/125µm or 62.5/125µm multimode fibres to interconnect units. Do not mix sizes if possible as this will reduce the operating distance. Patch cords should be of the same size as the main structural fibre.

Normal installation methods will use patch boxes at the end of a length of structural fibre with connections to the DAI via patch cords. This nominally gives the following attenuation:-

	50/125µm	62.5/125µm
2km of Fibre	3dB	3.5dB
2 x Patch panels	0.4dB	0.4dB
2 x Patch cords	0.5dB	0.5dB
TOTAL	3.9dB	4.4dB

The DAI's will normally operate with up to 6dB of attenuation allowing an additional intermediate patch if necessary although this should be avoided if at all possible.

Electromagnetic Compatibility

This equipment has been designed, manufactured and tested to conform to the European EMC directives EN55103-1 & EN55103-2 for classifications E2 and E4.

- Limitations as to use:**
1. The specified equipment is to be mounted into an earthed, steel equipment rack and not mounted adjacent to RF receiving equipment.
 2. Only approved Screened Audio cable terminated with suitable connectors are used for Audio interconnecting .

Manufacturers Information

The DAI-4 is manufactured in England by IKON AVS Ltd.

For service or warranty advice please initially contact your supplier.
Alternatively contact the manufactures at:-

IKON AVS Ltd
Unit 238 Ikon Trading Estate
Droitwich Road
Hartlebury
Worcestershire
DY10 4EU

Telephone:
(44) 01299 250991

Fax:
(44) 01299 250983

Website www.ikonavs.com

Technical support e-mail

support@ikonavs.com